

**FILFEX**

*friendly innovation*



**CUCIMAX**

**MAJOR LINE**

F O O D P R O C E S S I N G E Q U I P M E N T



- Gb** › MIXING DEVICE WITH THREE ARMS ENTIRELY REMOVABLE
- It** › MESCOLATORE A TRE BRACCI COMPLETAMENTE ASPORTABILE
- De** › 3-ARMIGES RUHRWERK KOMPLETT ABNEHMBAR
- Fr** › DISPOSITIF DE MÉLANGE À TROIS BRAS ENTIÈREMENT AMOVIBLE
- Es** › DISPOSITIVO DE MEZCLA CON TRES BRAZOS COMPLETAMENTE EXTIRPABLE

- Gb** › FRIENDLY SERVICE: QUICK ACCESSIBILITY TO THE MAIN COMPONENTS
- It** › FRIENDLY SERVICE: ACCESSIBILITÀ FACILE E VELOCE ALLA PRINCIPALE COMPONENTISTICA
- De** › FRIENDLY SERVICE: HAUPTBESTANDTEILE SIND LEICHT ERREICHBAR
- Fr** › FRIENDLY SERVICE: ACCESSIBILITÉ RAPIDE AUX PRINCIPAUX COMPOSANTS
- Es** › FRIENDLY SERVICE: RAPIDA ACCESIBILIDAD A LOS PRINCIPALES COMPONENTES



- Gb** › SECOND TEMPERATURE PROBE DIRECTLY IN CONTACT WITH THE FOOD. STANDARD ON CBTA
- It** › SECONDA SONDA DI TEMPERATURA A DIRETTO CONTATTO CON IL PRODOTTO STANDARD SU CBTA
- De** › ZWEITE TEMPERATURESONDE IN DIREKTEM KONTAKT MIT DEM KOCHGUT. SERIENMÄSSIG BEI CBTA
- Fr** › DEUXIÈME SONDE DE TEMPERATURE A DIRECT CONTACT AVEC LE PRODUIT. DE SÉRIE SUR CBTA
- Es** › SEGUNDA SONDA DE TEMPERATURA EN DIRECTO CONTACTO CON EL PRODUCTO. DE SERIE EN CBTA

- Gb** › DOUBLE-WALLED AUTOCLAVE LID WITH SEALING RING WITH A SINGLE JUNCTURE POINT
- It** › COPERCHIO AUTOCLAVE A DOPPIA PARETE CON GUARNIZIONE DI TENUTA AD UNICO PUNTO DI GIUNTURA
- De** › DECKEL STAHLBEHÄLTER MIT DOPPELTER WAND UND DICHTUNG MIT EINER VERBINDUNGSSTELLE
- Fr** › COUVERCLE AUTOCLAVE À DOUBLE PAROI AVEC GARNITURE D'ÉTANCHÉITÉ À UN SEUL POINT DE JONCTION
- Es** › TAPA AUTOCLAVE DE DOBLE PARED CON JUNTA HERMÉTICA CON SÓLO UN PUNTO DE UNIÓN



- Gb** › FILLING TAP (COLD/HOT WATER) WITH LITRE-COUNTER DEVICE FOR PRESETTING THE DESIRED QUANTITY OF WATER FROM THE BOARD
- It** › RUBINETTO DI CARICO ACQUA (CALDA/FREDDA) IN VASCA CON CONTALITRI IMPOSTABILE DA SCHEDA
- De** › HAHN ZUM EINFÜLLEN VOM WASSER (HEISS/KALT) IN DAS BECKEN, MIT LITERZÄHLER, DER AUF DER ELEKTRONISCHEN KARTE EINGESTELLT WERDEN KANN
- Fr** › ROBINET DE REMPLISSAGE EAU (CHAUDE/FROIDE) DANS LA CUVE, AVEC COMPTE-LITRES PROGRAMMABLE À PARTIR DE LA CARTE
- Es** › GRIFO PARA CARGAR AGUA (CALIENTE/FRÍA) EN CUBA, CON CUENTA-LITROS QUE SE PUEDE PROGRAMAR EN LA TARJETA ELECTRÓNICA



- Gb** › PRESSURE COOKING AT 0.5 BARS
- It** › COTTURA A PRESSIONE A 0,5 BAR
- De** › DAMPFGAREN MIT 0,5 BAR
- Fr** › CUISSON À PRESSION À 0,5 BAR
- Es** › COCCIÓN A PRESIÓN DE 0,5 BAR

Excellent under pressure

Ottima in  
impressione

**BRAISING PANS WITH MIXER**  
**BRASIÈRE MIXER**  
**BRATPFANNEN MIT MIXER**  
**SAUTEUSES MIXEUR**  
**SARTÉN MIXER**



■ **Gb** › Cucimax is a fundamental piece of equipment for the most efficient production centres. It is highly flexible in use guaranteeing the optimization of production processes and of human resources and is, therefore, both energy and cost-saving.

A unique new range of products has been created in order to offer further advantages: **Cucimax for pressure cooking**. Now you can pressure cook and mix at the same time: this new system combines autoclave cooking benefits with those of a presettable automatic mixing function.

Cucimax is a complete, sturdy and multifunctional device: from sauces to jams, from meat dishes to steamed vegetables, and much more!

■ **It** › Da sempre Cucimax è riconosciuta come un'apparecchiatura indispensabile per i centri di produzione più professionali. La grande elasticità di utilizzo permette di ottimizzare al meglio i processi produttivi e le risorse umane, garantendo così riduzione dei consumi e risparmio di denaro.

Al fine di offrire ulteriori vantaggi, è stata concepita una gamma unica al mondo: **Cucimax a pressione**. Ora è possibile cuocere in pressione e mescolare nello stesso momento, unendo i vantaggi della cottura in autoclave a quelli del miscelamento automatico regolabile.

Questa innovazione permette di utilizzare un prodotto davvero completo, robusto e seriamente multifunzionale. Dai sughi alle marmellate, dalle carni alle verdure al vapore, i campi di applicazione sono innumerevoli!

■ **De** › Schon immer ist Cucimax als ein Küchengerät bekannt, auf das in professionellen Gastronomiebetrieben nicht verzichtet werden kann. Der sehr flexible Einsatz ermöglicht eine Optimierung der Prozesse und der Arbeitskräfte und garantiert gleichzeitig dafür, dass Zeit und Energie gespart werden.

Um den Kunden noch weitere Vorteile zu bieten, wurde eine weltweit einzigartige Serie entwickelt, und zwar der **Dampf-Cucimax**. Jetzt ist das Dampfsgaren bei gleichzeitigem Umrühren

möglich, da zu den Vorteilen des Dampfsgarens jetzt auch das einstellbare automatische Rührwerk kommt.

Diese Innovation erlaubt den Gebrauch eines wirklich kompletten und robusten Multifunktionsgeräts, mit dem sich von Saucen über Marmelade bis hin zu Fleisch und gedämpftem Gemüse alles zubereiten lässt.

■ **Fr** › Depuis toujours, Cucimax est reconnu comme un appareil indispensable pour les centres de production plus professionnels. La grande souplesse d'usage permet d'optimiser au mieux les processus de production et les ressources humaines, en garantissant ainsi une réduction des consommations et une économie d'argent.

Dans le but d'offrir des avantages ultérieurs, une gamme unique au monde a été conçue: **Cucimax à pression**. Il est désormais possible de cuisiner sous pression et de malaxer en même temps, en unissant les avantages de la cuisson avec autoclave à ceux du malaxage automatique réglable.

Cette innovation permet d'utiliser un produit

vraiment complet, robuste et sérieusement multifonctionnel. En partant des sauces jusqu'aux confitures, des viandes aux légumes à la vapeur, les champs d'application sont innombrables!

■ **Es** › Desde siempre se considera a Cucimax como una instalación indispensable para los centros de producción de mayor profesionalidad. Su amplio abanico de empleo permite optimizar del mejor modo los procesos de producción y los recursos humanos, garantizando de esta forma no sólo la reducción del consumo sino también el ahorro de dinero.

Para ofrecer ulteriores ventajas, se concibió una gama única en el mundo: **Cucimax a presión**. Ahora se puede cocinar a presión y mezclar al mismo tiempo, uniendo las ventajas de la cocción en autoclave a las de mezcla automática regulable.

Esta innovación permite utilizar un producto realmente completo, robusto y seriamente multifuncional. Salsas, mermeladas, carnes, verduras al vapor: los campos de aplicación son infinitos!

## **RISPARMIAMO CON LA COTTURA A PRESSIONE** **SAVING WITH THE COOKING UNDER PRESSURE**

---

**Consumo energetico** \_\_\_\_\_ **- 40/60 %**  
**Lower energy consumption**

---

**Tempi di cottura** \_\_\_\_\_ **- 30/40 %**  
**Shorter cooking time**

---

**Consumo d'acqua in cottura** \_\_\_\_\_ **- 70 %**  
**Lower cooking water consumption**

---

**Riduzione del calo peso / Smaller shrinkage in weight**

---

**Maggiore qualità del prodotto finito / Better quality in end-item**

---

### **ALCUNE APPLICAZIONI CON CUCIMAX**

Soffritti \_\_\_\_\_ soffriggere  
Ragù/Sughi per primi piatti \_\_\_\_\_ brasare/cuocere  
Risotti \_\_\_\_\_ cuocere/mantecare  
Spezzatino \_\_\_\_\_ brasare/cuocere a pressione  
Verdure saltate \_\_\_\_\_ brasare  
Polenta \_\_\_\_\_ cuocere  
Caramello \_\_\_\_\_ cuocere  
Marmellate \_\_\_\_\_ cuocere  
Stufato di verdure \_\_\_\_\_ cuocere a pressione

### **MOST SUCCESSFUL PRODUCTS OF CUCIMAX**

Stews \_\_\_\_\_ braising and cooking under pressure  
Vegetables (especially green ones) \_\_\_\_\_ sautéing or roasting  
Chocolate \_\_\_\_\_ cooking  
Goulash \_\_\_\_\_ braising and cooking under pressure  
Braised tilapia \_\_\_\_\_ frying and braising  
Morrocan tajines \_\_\_\_\_ long braising  
Potatoes \_\_\_\_\_ steaming  
Chinese food \_\_\_\_\_ stir frying  
Sauces \_\_\_\_\_ searing and braising  
Karamell \_\_\_\_\_ cooking  
Beef bourguignon \_\_\_\_\_ sautéing and cooking under pressure  
Poultry \_\_\_\_\_ roasting  
Chicken \_\_\_\_\_ pressure cooking and braising  
Fried rice and legumes \_\_\_\_\_ frying and cooking under pressure  
Mashed potatoes \_\_\_\_\_ under pressure/cooking  
Shredded cabbage \_\_\_\_\_ braising and cooking under pressure  
Onions \_\_\_\_\_ sautéing  
Pasta-stuffings \_\_\_\_\_ long braising





## CARATTERISTICHE COSTRUTTIVE

- Vasca di cottura in AISI 304 (fondo spessore 12 mm).
- Recipiente con ribaltamento motorizzato su asse anteriore.
- Coperchio isolato a doppio mantello in AISI 304 bilanciato tramite molle a gas.
- Telaio autoportante in AISI 304.
- Rivestimenti esterni in AISI 304 finemente satinato.
- Rapida accessibilità alle principali parti funzionali (Friendly Service).
- Piedini in acciaio inox AISI 304 di differenti altezze regolabili per il livellamento dotati di copertura di protezione mobile per le operazioni di pulizia.
- Regolazione della temperatura da 20° a 220°C tramite sonda posizionata al di sotto della superficie di cottura e sonda in vasca (optional) a garanzia di una precisa rilevazione e di una elevata reazione del sistema riscaldante.

## MESCOLATORE

- Dispositivo automatico di mescolamento programmabile a tre bracci con raschiatori in teflon ed acciaio armonico, completamente asportabile per facilitare le operazioni di pulizia. Rotazione oraria ed antioraria con regolazione delle velocità e dei tempi (compreso tempo pausa), direttamente dal pannello comandi.
- Possibilità di installare raschiatore supplementare per parete laterale e palette aggiuntive (optional).

## VERSIONE GAS

- Riscaldamento tramite bruciatori tubolari ad alto rendimento in acciaio inox.
- Sistema automatico di accensione e sorveglianza di fiamma senza bruciatore pilota.
- Riscaldamento controllato dalla scheda elettronica con inserimento

automatico del minimo 2°C prima del SETPOINT impostato.

## VERSIONI ELETTRICHE

- Riscaldamento tramite resistenze corazzate in lega INCOLOY – 800.

## VERSIONE AUTOCLAVE

- Coperchio a doppia parete, rinforzato e bilanciato tramite molle a gas. Sistema di chiusura/apertura a doppia manovra per garantire la massima sicurezza. Guarnizione in gomma al silicone alimentare. Valvola di sicurezza tarata a 0,5 bar.



## CONSTRUCTIVE FEATURES

- Cooking vessel in stainless steel AISI 304 (bottom thickness 12 mm).
- Vessel with electric tilting on front part.
- Insulated lid with double cover in stainless steel AISI 304 balanced by means of gas springs.
- Self-supporting frame in stainless steel AISI 304.
- Outer cover in stainless steel AISI 304 fine satin finish.
- Adjustable feet in stainless steel AISI 304, even of different heights, with removable cover for cleaning operations.
- Friendly Service: quick accessibility to the main components.
- Temperature regulation from 20° to 220° C by means of a sensor located into the bottom just under the cooking surface or by a second probe in the vat (optional) to ensure a precise survey and quick reaction of the heating.

## MIXING DEVICE

- Automatic mixing device to program, with three arms and teflon and harmonic steel scrapers, entirely removable to make cleaning easier. Rotation in both directions, with speed regulation and time adjustment (including pausa time) directly from the control panel.
- Optional extra scraper to clean the wall of the vessel or to fix to the arms to move the product more.

## GAS VERSIONS

- Heating by means of stainless high efficiency steel tube burners.
- Automatic ignition and flame control system without pilot burner.
- Heating controlled by the electronic cards with automatic activation of the minimum power 2°C before the SETPOINT.

## ELECTRIC VERSIONS

- Heating by means of armoured elements in INCOLOY 800 alloy controlled by electronic card.

## AUTOCLAVE VERSIONS

- Double-wall Lid reinforced and springs loaded counterbalanced type with manual safety locking system controlled by two systems (lever and pressure).
- Alimentary silicone gummy gasket.
- Safety valve set at 0,5 bar.





Nuova scheda elettronica Firex,  
alta tecnologia in cucina.

*New Firex electronic control panel,  
cutting-edge technology in the kitchen.*

## SEMPLICITÀ ELETTRONICA

### Caratteristiche della scheda Firex:

- Touch screen da 7".
- Creazione e modifica di programmi di cottura, ciascuno di essi multifase.
- Cottura in modalità "Manuale".
- Impostazione multilingua dei messaggi.
- Facile da comprendere e da utilizzare.
- Garantisce di impostare tempi di cottura e temperature estremamente precise con valori da 20°C fino a 220°C.
- Possibilità di scegliere tra varie tipologie di cottura preimpostate: bollire in acqua, cuocere a pressione, rosolare;
- Permette di selezionare la quantità di litri d'acqua da caricare, se fredda

- o calda fino a 90°, ed effettua poi il carico automaticamente.
- Controlla fino a 3 diverse sonde di temperatura: nel fondo e in vasca a contatto con il prodotto per le cotture più delicate o speciali; anche a parete in caso optional "riscaldamento pareti" installato.
- Concede la possibilità di far iniziare la cottura in una data e un orario precisi.
- Fornisce semplici messaggi e icone per un corretto e sicuro utilizzo.
- Spiega in maniera chiara se c'è un allarme e a quale componente interno si riferisce.

- Collegamento USB.
- Impostazioni di differenti unità di misura.
- Autodiagnostica.
- Comando per il ribaltamento e ritorno della vasca di cottura.
- Impostazione programmi di mescolamento.
- Impostazione velocità di rotazione oraria ed antioraria.
- Regolazione tempi di mescolamento e pausa.
- Impostazione **riscaldamento pareti vasca a 3 zone.**

## ELECTRONIC SIMPLICITY

### Firex ETC Easy Touch Control control panel features:

- 7" touchscreen.
- Creation and editing of cooking programs, each of which is multi-phase.
- Cooking in "Manual" mode.
- Multilingual message setting.
- Easy to understand and use.
- Guaranteed setting of cooking times and extremely accurate temperatures from 20°C to 220°C.
- Controls at the most 3 different temperature probes: in the bottom,

- in the cooking vessel in direct contact with the food product for more accurate or specialist cooking, even in the wall in case of optional of "wall-heating".*
- Allows you to select the number of litres of water to load, cold or hot up to 90°, and then loads it automatically.
- Allows you to start the cooking on a specific date and time.
- Displays simple messages and icons for proper and safe use.
- Clearly explains if there is an

- alarm and to which internal component it relates.*
- USB connection.
- Settings for different units of measurement.
- Self Diagnostics
- Command for rollover and return of the cooking vessel.
- Setting of mixing programme with clockwise and anticlockwise rotation speed and pause time adjustment.
- 3-zone wall-heating setting.

## PRINCIPALI ACCESSORI E OPTIONAL

- Ruote
- Colino
- HACCP Controller
- Valvola di scarico in acciaio inox
- Doccetta per il lavaggio
- Presa di corrente
- Raschiatore supplementare laterale
- Carrelli

## MAIN OPTIONALS AND ACCESSORIES

- *Wheels*
- *Strainer*
- *HACCP Controller*
- *Washout stainless steel valve*
- *Cleaning shower*
- *Current tap 230 V*
- *Extra scraper for the wall*
- *Trolleys*

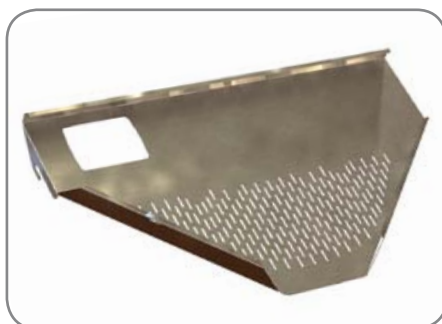

## BRASIERE MIXER / BRAISING PANS WITH MIXER

MOD.	Dimensioni Dimensions mm (L x P x H)	H1 mm.	Mixer velocità Mixer speed rpm	Mixer Coppia Mixer torque nm	Pressione Pressure bar	Vasca di cottura Cooking Vessel		Versione Gas Gas Version		Versione Elettrica Electric Version	
						Volume utile/totale Useful/overall capacity lt	Dim. vasca Pan dim. mm	Potenza gas Gas power rating Kw	Collegamento elettrico Elect. connection V/Hz	Collegamento elettrico Elect. connection V/Hz	Potenza elettrica Elect. power rating Kw
CBT 090	1455x1290 h. 950	1940	6-21	160	-	90/115	700 ø h. 300	22	250/50 AC - 1N + PE	400/50 3N+PE AC	13,5
CBT 130	1455x1290 h. 950	1940	6-18	191	-	130/154	700 ø h. 400	22	250/50 AC - 1N + PE	400/50 3N+PE AC	13,5
CBT 180	1655x1505 h. 950	2200	6-14	236	-	180/223	900 ø h. 350	33	250/50 AC - 1N + PE	400/50 3N+PE AC	21
CBT 310	1755x1560 h. 950	2240	4-10	353	-	310/353	1000 ø h. 450	49	250/50 AC - 1N + PE	400/50 3N+PE AC	29
CBT 130A	1455x1290 h. 950	1940	6-18	191	0,5	130/154	700 ø h. 420	22	250/50 AC - 1N + PE	400/50 3N+PE AC	13,5
CBT 180A	1655x1505 h. 950	2200	6-14	236	0,35	180/223	900 ø h. 370	33	250/50 AC - 1N + PE	400/50 3N+PE AC	21
CBT 310A	1755x1560 h. 950	2240	4-10	353	0,35	310/353	1000 ø h. 470	49	250/50 AC - 1N + PE	400/50 3N+PE AC	29

## VERSIONI / VERSIONS



## INSTALLAZIONE / INSTALLATION

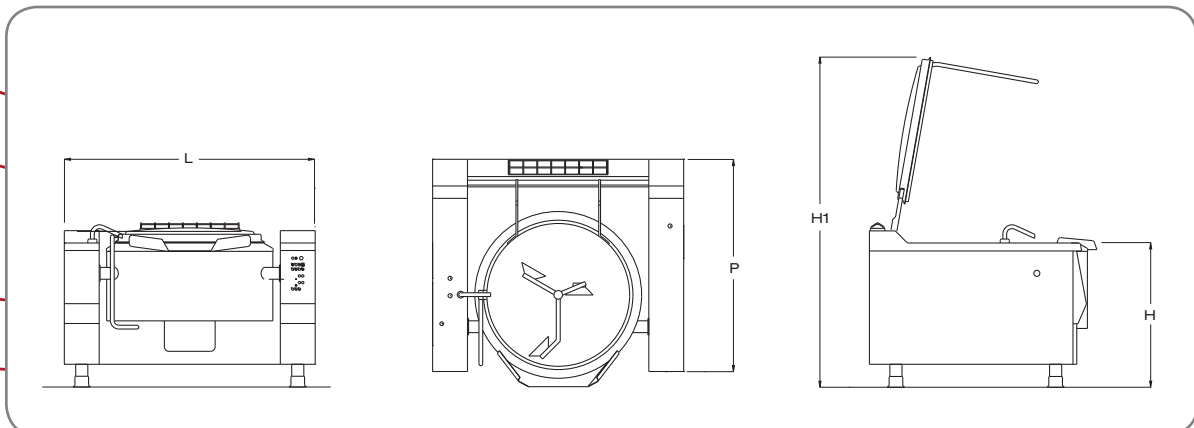



f i r e x . i t

**firex**<sup>®</sup>  
*friendly innovation*

COMPANY  
WITH QUALITY MANAGEMENT  
SYSTEM CERTIFIED BY DNV  
=ISO 9001:2000=



I dati riportati sono indicativi. L'Azienda si riserva di apportare in qualsiasi momento variazioni senza preavviso. / The information herein is indicative and not binding. The company reserves the right to make alterations at any time without notice. / Die vorliegenden Daten sind nicht bindend. Die Firma behält sich vor, jederzeit ohne Vorankündigung Änderungen vorzunehmen. / Les données reportées sont fournies à titre indicatif. Notre firme se réserve le droit d'effectuer des variations à tout moment sans préavis. / Los datos descritos son indicativos. El fabricante se reserva de aportar variaciones en cualquier momento sin previo aviso.

© 2009 - graphics by alidada.it - printed in Italy by grafiche amiga